

Implementing NERC Guidelines for Coordinating Generator and Transmission Protection

Charles J. Mozina

Consultant, Beckwith Electric Company
6190 118th Avenue North, Largo, FL 33773-3724 U.S.A.
Phone 727.544.2326 FAX 727.546.0121
Cmozina@aol.com

I. Introduction

Misoperations of generation protection during the U.S. east coast blackout on August 14, 2003 highlighted the need for better coordination of generator protection with generator capability, generator Automatic Voltage Regulator (AVR) control and transmission system protection. Generator protection misoperations also contributed to the 1996 California blackout. As a result of the 2003 blackouts, NERC (North Electric Reliability Council) has developed a “white paper” entitled “Power Plant and Transmission System Protection Coordination” [1]. The recommendations in the white paper are not yet a NERC standard, but will provide the technical input to producing a standard. This paper will provide practical guidance in implementing NERC-proposed guidelines (as outlined in the NERC white paper) for setting generator protection to coordinate with transmission protection. The paper will also address generator protection security issues that concern NERC that result from low system voltages, relay settings which restrict generator capability under emergency system conditions and coordination of generator protection with generator excitation and governor control.

II. NERC Analysis of 2003 Blackout Generator Trippings

During the 2003 blackout, a record number of generator trips (290 units totaling 52,743.9 MW) included thirteen types of generator protection relay functions that operated to initiate generator tripping. A list of the protection elements that tripped are summarized in Figure 1 and include: generator system backup protection, undervoltage, loss-of-field, overvoltage and inadvertent generator energizing protection. Of the 290 trippings, 96 are unknown trippings by relaying or controls which could not be identified from the monitoring available at these plants. There is no information available that directly addresses which of the 290 trippings were appropriate for the Bulk Electric System (BES) conditions, and which were nuisance trips. The above factors have motivated NERC to become pro-active in addressing the coordination of generator and Bulk Power System protection.

21- 8
24-1
27-35
32-8
40 - 13
46-5
50/27- 7
50BF - 1
51V - 20
78-7
59- 26
87T-4

UNKNOWN 96

TOTAL 290

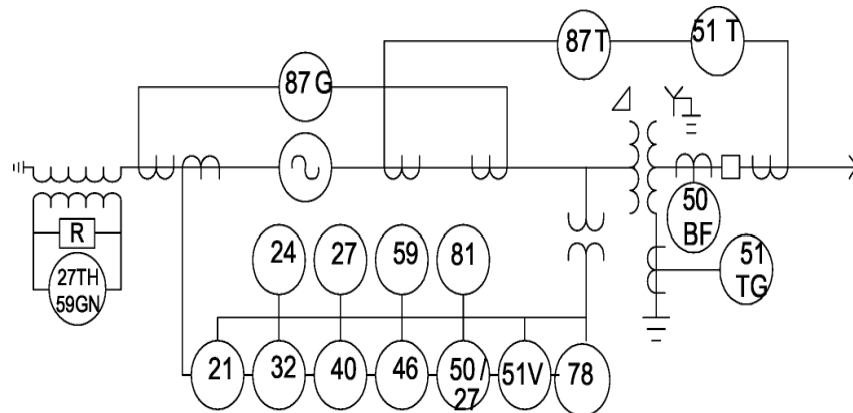

Figure 1. Breakdown of Generator Relays Tripped during 2003 East Coast Blackout [1]

III. Coordination of Generator and Transmission System Protection

Six relay functions underlined in Figure 1 accounted for the vast majority of trippings and are discussed in this paper.

System Backup Protection (21 & 51V): The Device 21 relay measures impedance derived from the quotient of generator terminal voltage divided by generator stator current. This relay function provides backup protection for system faults that have not been cleared by transmission system protective relays. The Device 51V, Voltage-Controlled or Voltage-Restrained Overcurrent Protection, is another method of providing backup for system faults. The NERC white paper states that it is never appropriate to enable both Device 51V and Device 21 within a generator digital relay and that the 21 impedance function is much preferred when coordination is with transmission line impedance relays.

There are two types of 51V relays—Voltage-Controlled and Voltage-Restrained. These overcurrent protective relays measure generator terminal voltage and generator stator current. Their function is to provide backup protection for system faults when the power system to which the generator is connected is protected by time-overcurrent protections. As stated previously, the preferred device for protection of generators that are interconnected to the bulk power transmission system is the 21 device because the protection on the transmission system is typically comprised of 21 relays. The coordination between these relays can be most effectively done because these relays have the same operating characteristics—i.e., they both measure impedance. The 51V backup relay is designed for applications where the system to which the generator is connected is protected by time overcurrent relaying. Because of the cost differences in electro-mechanical technology, the 51V relays were used to provide backup protection in place of the more expensive 21 relays which contributed to the number of misoperations that occurred during the 2003 East Coast blackout.

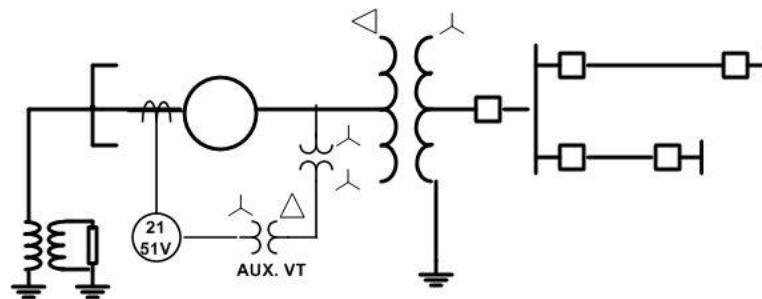

Figure 2. Connection of 21 and 51V System Backup Protection

Figure 2 shows a one-line connection diagram for these relays. These relays are set to respond to faults on the transmission system and their tripping is delayed to allow the transmission system protection to operate first. The degree to which the relays can be set to respond to transmission system faults is almost always limited due to loadability considerations. The generator steady-state load capability is described by the generator capability curve that plots the MW–MVAR capability.

21 Impedance Relay — As discussed previously, the 21 relay operates by measuring impedance. The generator capability must be plotted on the relay operating impedance plot to determine what the loadability is in relationship to the relay settings. Figure 3 describes how to do this conversion. The CT and VT ratios (R_c/R_v) convert primary ohms to secondary quantities that are set within the relay and KV is the rated voltage of the generator.

Typically, the phase distance relay's reach begins at the generator terminals and ideally extends to the length of the longest line out of the power plant transmission substation. Some factors impacting the settings are as follows:

1. In-feeds: Apparent impedance due to multiple in-feeds will require larger reaches to cover long lines and will overreach adjacent shorter lines. The apparent impedance effect occurs because the generator is only one of several sources of fault current for a line fault. This causes the impedance value of the faulted line to appear further away and requires a larger impedance setting to cover faults at the remote end of the line.
2. Transmission System Protection: If the transmission lines exiting the power plant have proper primary and backup protection, as well as local breaker failure, the need to set the 21 generator backup relay to respond to faults at the end of the longest lines is mitigated since local backup has been provided on the transmission system.

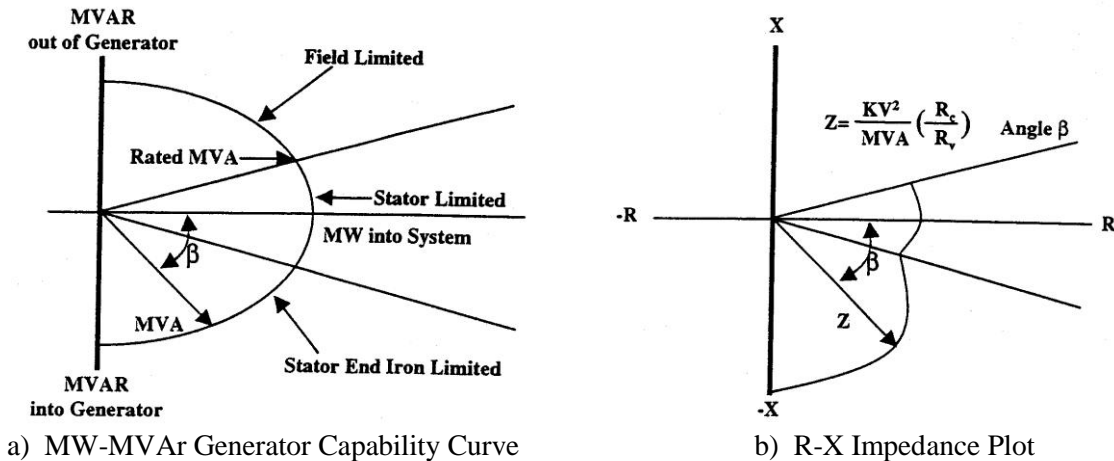

Figure 3. Transformation for Mw-MVAr to R-X Impedance Plot [3]

3. 21 Relay Loadability Test (IEEE): Settings should be checked to ensure the maximum load impedance ($Z_{Load} = kV^2 / MVA_G$) at the generator's rated power factor angle (RPFA) does not encroach into the 21 relay setting. A typical margin of 150-200% (50 to 67% of capability curve) at the rated power factor of the generator is recommended by IEEE C37.102-2006 [2] to avoid tripping during power swing conditions. A second criterion is a margin of 80 to 90% under the generator capability curve at the relay maximum torque angle setting of the 21 relay. Due to recent blackouts caused by voltage collapse, the 21 distance setting should be checked for proper operating margins when the generator is subjected to low system voltage. Note that the impedance is reduced by the square of the voltage. System voltage under emergency conditions can reduce to planned levels of 90 to 94% of nominal ratings. Utility transmission planners should be consulted for worst-case emergency voltage levels. In almost all cases, the loadability considerations limit the reach of the generator 21 backup relay setting.

21 Relay Loadability Test (NERC): The NERC white paper, however, suggests a more restrictive loadability test based on data obtained and analyzed for the 2003 blackout where the impact of field forcing by the generator AVR control resulted in a high Var output during system low voltage. Modern AVR control allows field current above rating (160-230%) for a short period of time (5-10 seconds) in an effort to raise system voltage. This results in a relative high output of reactive power (Mvars) at the same time the generator real power (Mw) is near normal and results in an impedance angle that tends to move into the 21 relay

trip characteristic. The NERC white paper suggests two setpoints that should be used to check the 21 setting during Bulk Power System extreme stress when field-forcing is taking place. These two load points are:

- #1) $MVA = 1.0 \text{ pu Mw} + J (1.5 \text{ pu Mw}) \text{ Mvars}$
- #2) $MVA = 0.4 \text{ pu Mw} + J (1.75 \text{ pu Mw}) \text{ Mvars}$

Note that the reactive power (Mvars) is defined in terms of generator MW rating where 1.0 pu is the MW rating of the generator. The methods outline in Figure 3 can be used to convert the Mw and Mvar values to impedance and they can be plotted on an R-X diagram of the 21 relay setting.

Figure 4 shows the plot of both IEEE and NERC loadability tests on an R-X diagram for a typical large generator. It can be seen that the NERC loadability test is much more restrictive and results in a 21 setting that will be more restrictive in responding to fault on the power system. With very limited backup for transmission system faults, the transmission system line protection will need to have delineated primary and backup as well as local breaker failure. This is so no single contingency failure will require remote backup tripping by the generator 21 protection which has limited response to remote transmission faults. Both IEEE and NERC require that the time delay for the 21 relay should be set longer than the transmission lines backup and breaker failure protection with appropriate margin for proper coordination and be set so that it does not operate on stable power swings.

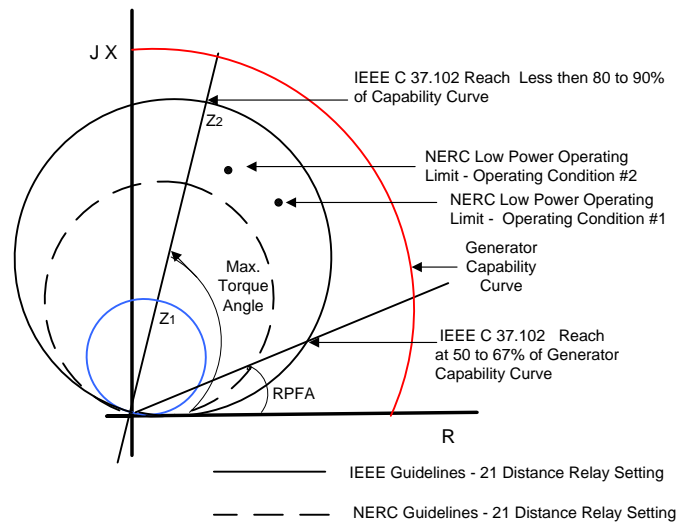

Figure 4. Generator Phase Distance Backup Protection Settings

51V Voltage Overcurrent Relay — There are two types of 51V relays—Voltage-Controlled (51V-C) and Voltage-Restrained (51V-R). These overcurrent protective relays measure generator terminal voltage and generator stator current. The use of a voltage control is necessary due to the fact that the generator, when subjected to a fault condition, will go through its generator decrements with the short circuit current reducing to near or below full load current over time. Figure 5 illustrates this current decay. The impedance of the generator changes (X_d'' , X_d' , X_s) to higher values with time as shown in Figure 5 and the speed of decay is determined by the generator field time constants (T_d). Since the 51V relay needs to be coordinated with system backup protection as well as breaker failure, the level of current at the time of tripping is substantially reduced from the current at the inception of the fault. Thus the need for a voltage input to provide the sensitivity required to detect a fault in backup time.

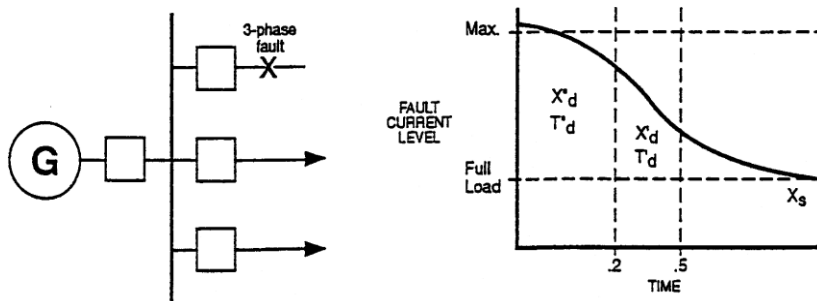

Figure 5. Generator Decrement Fault Current Decay

When the 51V-C voltage-controlled relay is subjected to a fault, the voltage element will enable the overcurrent element permitting operation of the sensitive time-overcurrent function. The overcurrent pickup level will generally be set below the generator fault current level as determined by synchronous reactance (X_s). Generally, the overcurrent pickup level will be set below generator full load current. The voltage function must be set such that it will not enable the overcurrent element for extreme system contingencies. The 51V-C must be coordinated with the longest clearing time, including breaker failure, for any of the transmission backup protection including breaker failure. A time margin of 0.5 seconds is recommended. A voltage setting of 0.75 per unit or less is recommended by the NERC document to prevent improper operation during system low voltage conditions that are recoverable events. Typically the pickup value of the overcurrent relay is determined by using the synchronous reactance (X_s) for the generator impedance when calculating the fault on the system for which the relay should operate to provide proper backup protection. This provides the lowest current on the generator decrement curve shown in Figure 5. For coordination with other overcurrent or distance relays transmission system, the minimum generator impedance (X_d'') is used to provide the maximum fault current from the generator for coordination with transmission system relaying.

The 51V-R relay changed its pickup with terminal voltage. Figure 6 shows the time versus relay pickup relationship. For the 51V-R function, the voltage function will not prevent operation for system loading conditions under low system voltage condition. The overcurrent function must be set above generator full-load current. IEEE C37.102 recommends the overcurrent function to be set 150% above full-load current. The NERC documents states that at 75% of generator-rated voltage, the overcurrent pickup value should be greater than the generator full-load current. Applying this NERC criterion with a 150% overcurrent pickup at rated voltage, the margin over generator-rated current at 75% generator terminal voltage is 113%.

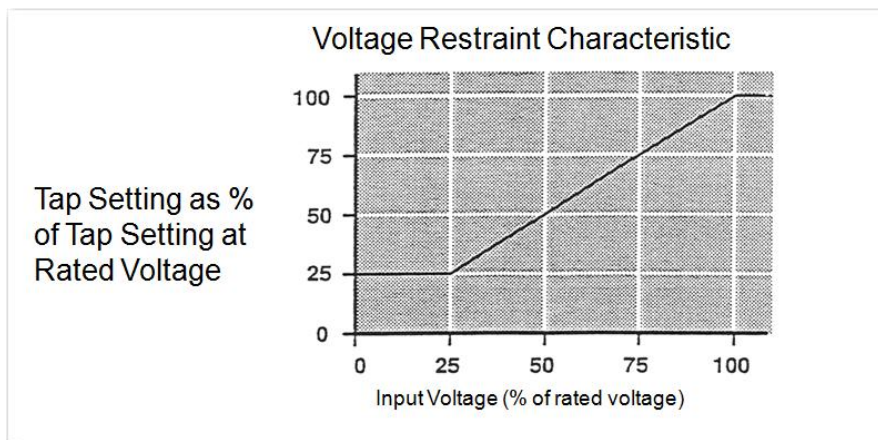

Figure 6 51V-C Relay Pickup versus Voltage Characteristic

Undervoltage Protection (27): Undervoltage (Device 27) tripping of generators was the single biggest identifiable cause of generator tripping during the 2003 blackout. The device 27 measures generator terminal voltage. IEEE Standard C37.102 – IEEE Guide for AC Generator Protection [2] – does not recommend use of the 27 function for tripping, but only to alarm to alert operators to take necessary actions. Undervoltage alarms as experienced by hydro, fossil, combustion and nuclear units are an indicator of possible abnormal operating conditions such as excitation problems and thermal issues within the unit. Other alarms from RTDs and hydrogen pressure are better indicators of thermal concerns. If function 27 tripping is used for an unmanned facility, the settings must coordinate with the stressed system condition of 0.85 per unit voltage and time delays set to allow for clearing of system faults by transmission system protection, including breaker failure times. The recommended time delay is 10 seconds or longer.

Manufacturers recommend operator action up to and including reduction in unit output rather than a unit trip. Generators are usually designed to operate continuously at a minimum voltage of 95% of its rated voltage, while delivering rated power at rated frequency. Operating a generator with terminal voltage lower than 95% of its rated voltage may result in undesirable effects such as reduction in stability limit, import of excessive reactive power from the grid to which it is connected, and malfunctioning of voltage-sensitive devices and equipment. Low generator voltage can affect the plant auxiliary system supplied from the generator auxiliary transformer. Auxiliary systems at steam plants contain a large number of motors, which are constant KVA devices that can be overloaded due to low voltage. The lower their operating voltage, the more current the motor draws. Thus, plant auxiliary system motors can trip, and have tripped, via their thermal protection for low generator terminal voltage. Generator undervoltage relays should not be used to protect these motors. The thermal protection on the motors should be the protection element that protects these motors from overload.

At nuclear plants, the voltage on the I-E busses is typically monitored by undervoltage relays. If the I-E voltage drops to a point where the plant cannot be safely shut down, the diesels are started and the I-E loads transfer to the diesels. The plant then must be shut down if system voltage does not return to normal. The nuclear plant should provide the transmission system operator the level of the I-E separation voltage so that planning studies can recognize the possible tripping of the nuclear plant due to low system voltage.

Inadvertent Energizing Generator Protection (27/50): Inadvertent or accidental energizing of off-line generators has occurred often enough to warrant installation of dedicated protection to detect this condition. Operating errors, breaker head flashovers, control circuit malfunctions, or a combination of these causes has resulted in generators being accidentally energized while off-line.

The problem is particularly prevalent on large generators that are commonly connected through a disconnect switch to either a ring bus or breaker-and-a-half bus configuration. Figure 7 illustrates this type of bus configuration. These bus configurations allow the high voltage generator breakers to be returned to service as bus breakers—to close a ring bus or breaker-and-a-half bay when the machine is off-line. The generator, under this condition, is isolated from the power system through only the high-voltage disconnect switch. While interlocks are commonly used to prevent accidental closure of this disconnect switch, a number of generators have been damaged or completely destroyed when interlocks were inadvertently bypassed or failed and the switch accidentally closed. When a generator on turning gear is energized from the power system (three-phase source), it will accelerate like an induction motor. The generator terminal voltage and the current are a function of the generator, transformer, and system impedances. Depending on the system, this current may be as high as 3 pu to 4 pu and as low as 1 pu to 2 pu of the machine rating. While the machine is accelerating, high currents induced into the rotor may cause significant damage in only a matter of seconds. If the generator is accidentally back-fed from the station auxiliary transformer, the current may be as low as 0.1 pu to 0.2 pu. While this is of concern and

has occurred, there have not been reports of extensive generator damage from this type of energizing; however, auxiliary transformers have failed.

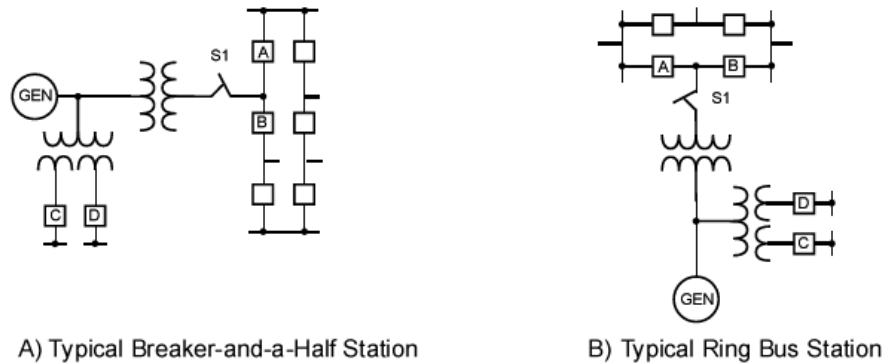

Figure 7. One-Line Diagrams for High-Voltage Generating Stations

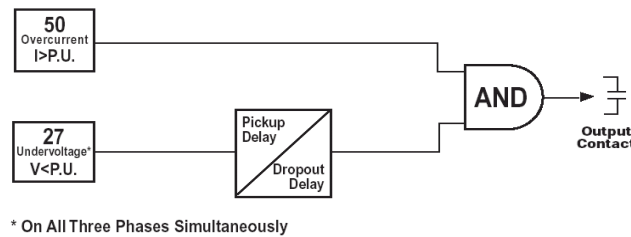

Figure 8. Inadvertent Energizing Protection Scheme Logic

The most commonly installed scheme to provide protection for inadvertent energizing protection is a voltage-controlled overcurrent scheme shown in Figure 8. When the unit is removed from service, an undervoltage relay (27) operates after a time delay (pickup timer setting) set longer than fault-clearing time for transmission system backup faults to arm an instantaneous overcurrent relay (50). In many cases, the overcurrent relay (50) is set below generator full load to provide the necessary sensitivity to detect inadvertent energizing. The logic shown in Figure 8 provides rapid detection of an inadvertent energizing event. The voltage relay pickup must be set lower than any steady-state emergency low voltage condition that can occur when the system is under extreme stress conditions. When the generator is returned to service and the voltage exceeds the 27 relay setting, the scheme is automatically removed from service after an appropriate time delay (drop-out timer setting). The inadvertent energizing protection must only be in-service when the generator is out-of-service and disabled when the generator is on-line. During the August 14, 2003 blackout event, seven units using this scheme operated on in-service generators due to depressed voltage below the 27 setting and unnecessarily tripped those units. It is believed that these units had the undervoltage supervision set above the recommended setpoint of less than 50% of generator-rated voltage.

Loss-of-Field Protection (40): Partial or total loss-of-field on a synchronous generator is detrimental to both the generator and the power system to which it is connected. The condition must be quickly detected and the generator isolated from the system to avoid generator damage. A loss-of-field condition which is not detected can have a devastating impact on the power system by causing a loss of reactive power support, as well as creating a substantial reactive power drain. This reactive drain, when the field is lost on a large generator, can cause a substantial system voltage dip. When the generator loses its field, it operates as an induction generator—causing the rotor temperature to rapidly increase due to the slip-

induced eddy currents in the rotor. The high reactive current drawn by the generator from the power system can overload the stator windings.

There are two widely-applied methods for detecting a generator loss-of-field condition. A two-zone distance relay approach is used in both schemes to provide high-speed detection. Figure 9 illustrates both approaches. The zone 2 impedance circle diameter is set to equal to the generator synchronous reactance (X_d) (or 1.1 times X_d in one approach) and is offset downward by half of the generator transient reactance (X_d'). A directional element is used in one approach so the zone 2 unit will not operate for forward direction faults. The operation of the zone 2 element is delayed approximately 30-45 cycles to prevent misoperation during a stable transient power swing. The zone 1 used in both approaches has a slight time delay of 5 to 6 cycles and is used for high-speed detection of more severe loss-of-field conditions. The loss-of-field setting must be checked for coordination with the generator capability curve, AVR under-excitation limiter setting and should not trip for stable power swings. Figure 9 illustrates this coordination on an R-X impedance diagram.

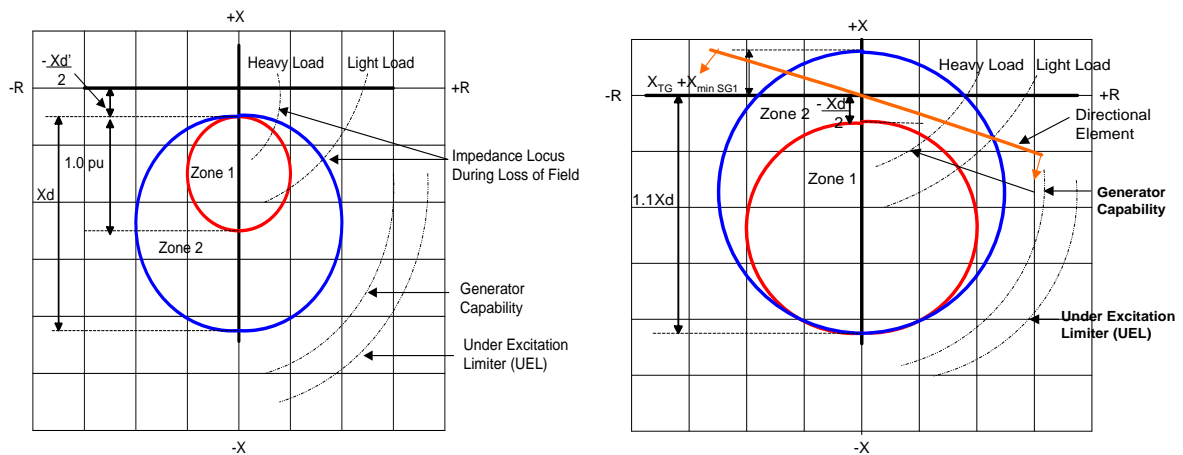

Figure 9. Modern Loss-of-Field Protection Using Two-Zone Off-Set Mho Method

System stability studies should be conducted to see if the time delays mentioned previously are sufficient to prevent inadvertent tripping during stable power swings for both steady-state and transient-stability conditions. The NERC document recommends that the loss-of-field function settings be provided to the Planning Coordinator by the Generator Owner so that the Planning Coordinator can determine if any stable swings encroach long enough in the loss-of-field function trip zone to cause an inadvertent trip. The Planning Coordinator has the responsibility to periodically verify that power system modifications do not result in stable swings entering the trip zone(s) of the loss-of-field function causing an inadvertent trip. If permanent modifications to the power system cause the stable swing impedance trajectory to enter the loss-of-field characteristic, then the Planning Coordinator must notify the Generator Owner that new loss-of-field function settings are required. The Planning Coordinator should provide the new stable swing impedance trajectory so that the new loss-of-field settings will accommodate stable swings with an adequate time delay. The new settings must be provided to the Planning Coordinator from the Generator Owner for future periodic monitoring. In a limited number of cases, conditions may exist that coordination cannot be achieved for every generating unit. In such cases, coordination may be deemed acceptable if tripping does not cascade and is limited to a small amount of generation (as a percentage of the load in the affected portion of the system). Protection models must be added to system models for any units for which coordination cannot be obtained.

Overvoltage Protection (59): The device 59 overvoltage protection uses the measurement of generator terminal voltage. Over-voltage protection is for preventing an insulation break-down from a sustained overvoltage. The generator insulation system is capable of operating at 105% overvoltage continuously. Beyond 105%, sustained overvoltage conditions should normally not occur for a generator with a healthy voltage regulator, but it may be caused by the following contingencies: (1) defective AVR operation, (2) manual operation without a voltage regulator, and (3) sudden load loss. Figure 10 shows the connection of the 59 relay on a typical generator.

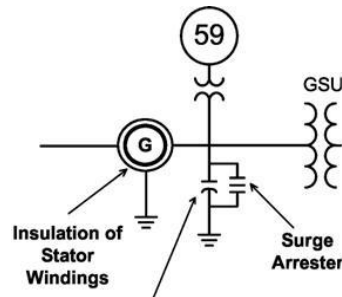

Figure 10. Overvoltage Relay with Surge Devices Shown Connected to Stator Windings

There are no coordination requirements with the transmission protective relays for system faults given the high voltage setpoint and long delay of tens of seconds or longer. Additionally, most system fault conditions would cause a reduction in voltage. The misoperation that occurred during the 2003 blackout appeared to be caused by setting the relay with too short a time delay such that short time system overvoltage conditions during the event triggered the trippings. The following is a NERC example of setting the 59T and 59I function time delays.

Step 1 — $V_{\text{Nominal}} = 120\text{V}$

Step 2 — $59\text{T} = 105\%$ of 110% of $V_{\text{Nominal}} = 1.05 \times 1.10 \times 120\text{V} = 139\text{V}$ (1.155 pu),
with a time delay of 10 seconds or longer.

Step 3 — $59\text{I} = 105\%$ of 130% of $= 1.05 \times 1.30 \times 120\text{V} = 184\text{V}$ (=1.365 pu) with no time delay

It is suggested that, for creditable contingencies where overvoltage may occur, all shunt reactors near the generator be placed in service or all capacitor banks near the generator be removed from service prior to the 10 second-trip limit on the generator. Overvoltage can also occur when EHV transmission lines exiting the plant are tripped only at the terminal remote from the generating station. These unloaded lines have high-shunt capacitance that can raise generator terminal voltage.

Figure 11 provides an example of a voltage regulator response to load rejection where transmission line protection has tripped to cause a sudden loss of generator load. The regulator causes the generator to operate back near nominal voltage in about two seconds, well before any action by the overvoltage protection.

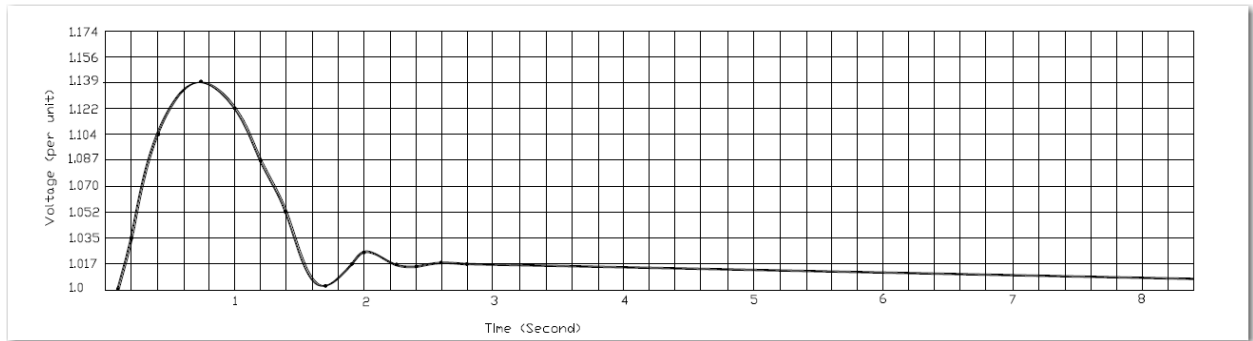

Figure 11. Typical Example of Load Rejection Data for Voltage Regulator Response Time

IV. Coordination of Generator Protection with Generator Control

In North America, the NERC requires that system operators have positive assurance that generator excitation controls are in service and that specified generator reactive power is available. Assurance of this capability requires periodic testing of the AVR control to ensure it is operating properly and that it coordinates with the protection system. NERC is also requiring specific data for generators that are interconnected to the power grid and above a specific MVA size (in some cases, as small as 10 MVA). This information includes:

- Reactive capability range of the generator
- Excitation system models with data validated by tests
- Generator characteristics and synchronous, transient and subtransient reactances that are verified by test data
- Excitation limiters that are modeled and verified
- Generator protection relays that are verified that they coordinate with excitation limiters. (The methods for doing this coordination are described in this paper.)
- An excitation system that must be operated in the automatic mode.
- For generators operating in the western United States, a power system (PPS) that must be enabled and a verified model provided.

These NERC requirements [4] point out the importance of the generator's AVR control and associated excitation system in helping avoid system blackouts. During system stress conditions, the AVR limits are frequently challenged when system conditions such as voltage collapse or steady-state stability limits might be approached. The AVR control limiters play an important role in making sure the generator is operated within its capability while providing short-time positive and negative field-forcing to help stabilize both high- and low-transient system voltage due to fault and load rejections.

Effects of Voltage Depression on AVR Control and Limiters: The generator AVR uses the generator terminal voltage and phase current to calculate generator operating conditions as shown in Figure 12. By comparing the actual point of operation to the desired level, the AVR determines when it is appropriate to adjust the generator field current to maintain the desired generator operating voltage. Depending on the specific manufacturer, the AVR limiter settings may change with voltage. Some AVR limiters change as the square of the voltage (90% voltage results in 81% of the setting), while others are proportional with the voltage (90% voltage results in 90% of the setting). Still other limiters may not change with voltage at all. To assure proper operation for all conditions, the specific limiter voltage variation characteristic should be identified when setting the limiter and the performance at the lowest credible operating voltage examined.

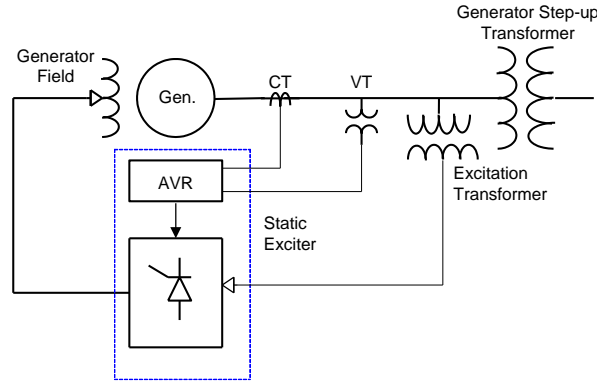

Figure 12. Basic Static Excitation System

AVR Limiters and Response During Disturbances: In disturbances where short circuits depress the system voltage, electrical power cannot fully be delivered to the transmission system. Fast response of the AVR and excitation system helps to increase the synchronizing torque to allow the generator to remain in synchronism with the system. Field-forcing techniques are used to rapidly increase field current above the steady-state rating for a short time to increase synchronizing torque to enhance generator stability. Negative field-forcing provides fast response for load rejection and de-excitation during internal generator faults. After the short circuit has been cleared, the resulting oscillations of the generator rotor speed with respect to the system frequency will cause the terminal voltage to fluctuate above and below the AVR setpoint. AVR control limiters are used to prevent the AVR from imposing unacceptable conditions upon the generator. These controls are the maximum and minimum excitation limiters. The overexcitation limiter (OEL) prevents the AVR from trying to supply more excitation current than the excitation system can supply or the generator field can withstand. The OEL must limit excitation current before the generator field overload protection operates. The under excitation limiter (UEL) prevents the AVR from reducing excitation to such a low level that the generator is in danger of losing synchronism. The UEL must be coordinated with the generator capability, stability limits and the loss-of-field relay as discussed in Section III of this paper.

Using Power System Stabilizers (PSS) to Maintain Stability: As discussed previously, a fast-acting AVR is very desirable to help stabilize generator voltage during major disturbances such as fault or load rejection situations. However, these fast-acting systems can also contribute a significant amount of negative damping that results in amplifying small, low-frequency MW oscillations that can occur in a power system. After a fault, these MW oscillations may vary in frequency—typically from 0.1 to 2 Hz. This problem has been most often associated with the western region of the U.S. and Canada, where transmission lines connect generators to the load center over long distances. It can, however, occur anywhere the load is remote from the generation. When this occurs, the generator can eventually be driven unstable, lose synchronism and slip a pole. To address this problem, a Power System Stabilizer (PSS) is utilized in conjunction with the generator AVR to provide positive damping when megawatt oscillations occur. The PSS is a low frequency filter that prevents the AVR from amplifying low frequency MW oscillations. With the aid of a PSS, the excitation system will vary the generator field current to apply torque to the rotor to damp these oscillations. PSSs are required by NERC/Western Electric Coordinating Council (WECC) in the western U.S. and Canada for generators exceeding 30 MVA, or groups of generators exceeding 75 MVA with excitation systems installed after November 1993.

Turbine Controls: During recent blackouts, turbine controls have improperly operated due to the voltage dips and frequency transients caused by system short circuits. These voltage dips have resulted in

improper operation of Power Load Unbalance (PLU) controls as well as gas turbine “lean blowout” trippings.

Power Load Unbalance (PLU) Trippings: PLUs are applied on large steam generators to avoid over-speed tripping during full load rejection by closing, and then opening, steam valves to reduce mechanical energy and avoid over-speed unit tripping. The PLU control scheme automatically initiates closing of intercept and control valves within 10 ms. The scheme is triggered by an unbalance of steam and electric power, which exceeds 40%. During system fault conditions, system voltage is reduced. The reduced voltage results in a reduction in the electrical power (MW) output of the generator—unbalancing the electrical and steam power. PLUs have improperly operated for these system conditions. These improper generator trippings have resulted in a Midwest near-blackout and a blackout in New Mexico. The manufacturer states the PLUs are not designed to operate for system fault conditions. A PLU setting restricts operation through a rate of change of power setting, which can discriminate between load rejection and system fault conditions.

There is also a software problem in the GE MKVI turbine control PLU. It has improperly operated for system faults. Once activated, it closes both the control and intercept valves but fails to open the control valve which results in a unit trip. GE has issued a technical information letter (TIL 1534-2) to upgrade the scheme to prevent misoperations. NERC may also issue an alert letter to make generator owners aware of the problem.

Gas Turbine “Lean Blowout” Tripping: An operating error resulted in a transmission system 138KV fault in south Florida remaining on the system for 1.7 seconds. During the protracted fault, voltage locally went to near-zero, which effectively reduced the area load and thereby caused area generators to accelerate. Indications are that six combustion turbine (CT) generators within the region that were operating in a lean-burn mode (used for reducing emissions) tripped offline as result of a phenomenon known as “turbine combustor lean blowout.” As the CT generators accelerated in response to the frequency excursion, the direct-coupled turbine compressors forced more air into their associated combustion chambers at the same time as the governor speed control function reduced fuel input in response to the increase in speed. This resulted in what is known as a CT “blowout,” or loss of flame, causing the units to trip offline. Generator owners and operators are encouraged by NERC to consult their CT manufacturers to understand and identify the plant’s susceptibility to “turbine combustor lean blowout” as a result of a system over-frequency transient and work with them to identify steps that may mitigate this issue.

V. Conclusions

Recent misoperations of generation protection during major system disturbances have highlighted the need for better coordination of generator protection with generator capability, generator excitation control (AVR) limiters and transmission system protection. This paper provides a brief summary of the NERC white paper recommendation for coordinating generator and transmission system protection and compares it to existing IEEE guidelines. In most cases, with a few notable exceptions, the recommendations are the same. In a few areas, however, the NERC document suggests more stringent requirements based on analysis of data from the 2003 East Coast blackout.

This paper also discusses in detail the important role the generator AVR and turbine control play during major system disturbances. Since most recent major power system disturbances are the result of voltage collapse, generator protection and turbine control must be secure during low-voltage system conditions while still providing generator protection. In addition, the generator AVR needs to properly control VAr support to rapidly stabilize system voltage during major disturbances.

VI. References

- [1] “Power Plant and Transmission System Protection Coordination,” NERC Technical Report, Revision 1 July 2010. (available on the NERC website).
- [2] IEEE Guide for AC Generator Protection, ANSI/IEEE C37.102-2006.
- [3] “Protective Relaying Theory and Applications” edited by Walter A. Elmore, ABB Power T&D Company Inc. Coral Springs, FL, 1994.
- [4] “Final Report on the August 14, 2003 Blackout in the United States and Canada: Causes and Recommendations,” U.S. – Canada Power System Outage Task Force, April 5, 2004.

VII. About the Author



Charles (Chuck) Mozina is a Consultant for Beckwith Electric. He is a Life Fellow of the IEEE, an active 25-year member of the IEEE Power System Relay Committee (PSRC) and the past chairman of the Rotating Machinery Subcommittee. Mozina is active in the IEEE IAS committees that address industrial protection. He is a former U.S. representative to the CIGRE Study Committee 34 (now B-5) on System Protection. Mozina has a Bachelor of Science in Electrical Engineering from Purdue University. He has over 25 years of experience as a protection engineer at Centerior Energy (now part of FirstEnergy), a major investor-owned utility in Cleveland, Ohio where he was the Manager of the System Protection Section. He is a registered Professional Engineer in the state of Ohio. Mozina has authored a number of papers and magazine articles on protective relaying.